

# Cross Buck Fence Gate | Installation Guide

# Gate Assembly

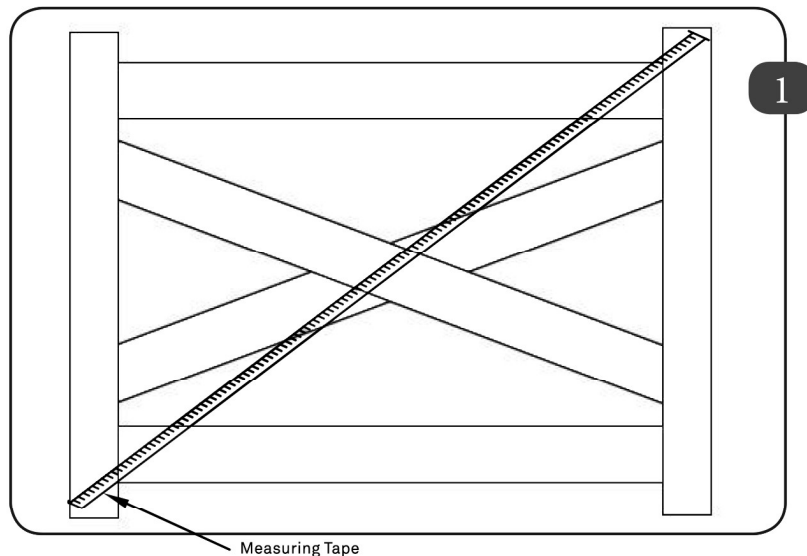

1. Locate, lay out and dry-assemble all parts of the gate including posts and rails. Do not use glue.
2. For a single gate, cut the rails to a length 2 1/2" shorter than the gate opening size (gate opening size is the distance between the gate posts). For example, if your gate opening size is 96", cut each of the rails to 93.5".
3. For a double gate, the gate will need to be 4" shorter than the gate opening size. You will need to cut 2" off of each gate for a total of 4". For example, if your gate opening size is 192" (192" divided by 2 equals 96") then cut each rail to 94" wide.
4. Insert the top and bottom rails into the sockets by lightly tapping the end post & sockets into the rails using a soft face non-marking mallet. Next insert the cross rails. The cross rails are notched on one side. The notched side will go into the second route hole from the top on either side. Be sure the cap holes are in the up position.

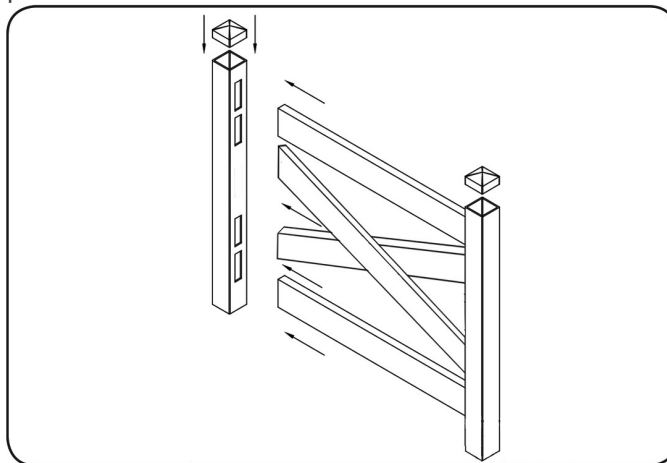

1. Remove the first gate post to flip it and insert a 1/8" bead of glue around the inside of the two pockets down about 1/4" from the top of each pocket. Do next step quickly!
2. After glue is in the pockets of the first post, flip posts to quickly insert the rails into the pockets.
3. Be sure to firmly insert the rails. The adhesive will set in 45 seconds.
4. Insert screw into the top and bottom socket from inside the post.

# Gate Assembly

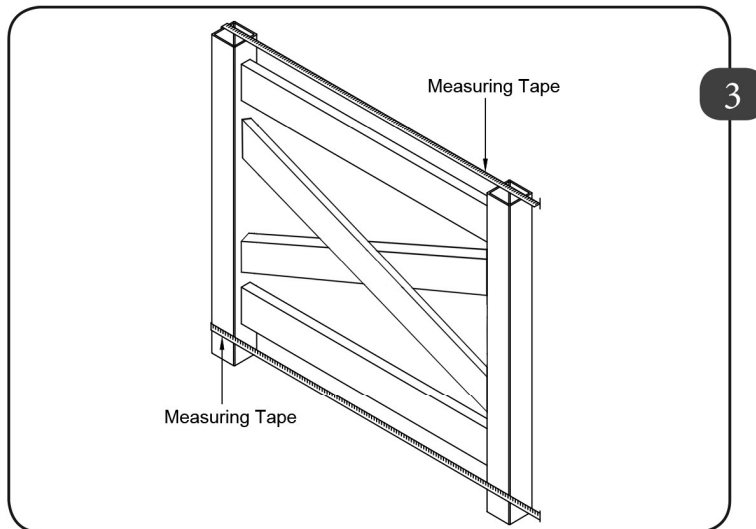

1. Repeat the previous steps for the other post. This may take some assistance to do before the adhesive sets.
2. Measure the top and bottom of gate to ensure both lengths are the same.

## SINGLE GATE INSTALLATION

1. Determine the direction the gate is to swing, usually swings away from yard. Check your local codes!
2. Install aluminum insert on the hinge side prior to the installation of the gate.
3. Locate and follow hardware installation instructions.

The gate will be mounted to be flush with the side of the fence that the gate will be swinging. See the illustration below. Be sure the gate will be high enough to clear obstructions such as snow. The gate posts should be cut on site as needed. Some installers cut the gate posts off at the bottom of the bottom gate pocket. **DO NOT** cut into the gate pocket.

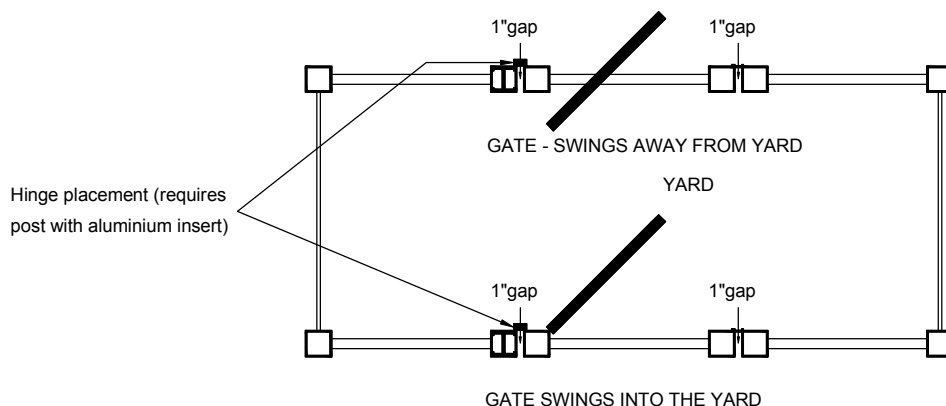

# Gate Installation

## DOUBLE GATE INSTALLATION

1. Follow the same instructions as per a single gate when installing the hinges for both gates.
2. To calculate the variances for the latch you must treat the fixed gate as if it were a standard fence panel.
3. The ideal hardware installation on a double gate should have equal spacing between posts and gates.
4. Install the drop rods to post of the fixed gate.

